

## **Principal Technology Leadership Practices and Teacher Acceptance of School Management System (SMS)**

*Amalan Kepimpinan Teknologi Pengetua Dan Penerimaan Guru terhadap Sistem Pengurusan Sekolah*

Leong Mei Wei  
Sathiamoorthy Kannan  
Shafinaz Bt A. Maulod

*Email: lmw5098@gmail.com*

### **Abstract**

*This study aims to investigate the level of principal technology leadership practices and teacher acceptance and use of SMS in Negeri Sembilan secondary schools. This is a non-experimental quantitative research using survey technique through the administration of a set of questionnaire that comprised teacher demographic variables, principal technology leadership practices and teacher acceptance and use of SMS. There are 417 returned questionnaires have been analyzed. The findings showed that teachers in Negeri Sembilan secondary schools perceived that their principals practice a high level of technology leadership and they also rated themselves with high levels of acceptance and use of SMS. Furthermore, data indicated that there was a statistically significant positive correlation that is moderately strong between principal technology leadership practices and teacher acceptance and use of SMS. In addition, the multiple regression analysis showed that digital citizenship and visionary leadership are the two principal technology leadership practices dimensions that are statistically significant predictors of teacher acceptance and use of SMS. The moderating effect test revealed that gender, age, educational level, and experience in using the computer are not the moderators, except for teaching experience that is moderating the relationship between principal technology leadership practices and teacher acceptance and use of SMS.*

**Keywords:** *Technology leadership, leadership practices, acceptance, use of SMS, secondary school*

### **Introduction**

Globalization and the advancement of information and communication technology (ICT) have created a new knowledge-driven economy era. Consequently, many governments have started to invest heavily on ICT to address the demands of this digital and information age (Ministry of Education Malaysia, 2010). Avci Yucel and Gulbahar (2013) noticed that the progress of web-based technology together with the exponential growth of internet accessibility has caused the widespread usage of web-based applications across many different disciplines and this has brought some visibility competitiveness in people's workplace (Haughey, 2006). The prominent role of ICT could be seen in advancing knowledge and is a necessary skill for effective functioning in the modern world (Adeyemi & Olaleye, 2010). Hence, the educated workforce is vital to remain competitive because the state of the education system today is the best predictor of Malaysia's competitiveness tomorrow (Ministry of Education Malaysia, 2013b).

Educational technology has altered the landscape of what learners know and how they learn (Papa, 2011). The advancement of technology has significantly changed the Malaysian educational landscape (Wong, Mas Nida, Abu Daud, & Othman, 2011). In 1996, Malaysian government have launched the Multimedia Super Corridor (MSC) to accelerate its entry into the Information Age as the major national initiative to transform Malaysian into a knowledge-based society with ICT advancement that in line with the country's ambitions in achieving fully developed status by the year 2020. Smart School, one of the seven flagships under the MSC aimed to integrate ICT into school environment to equip the next generation to become more competitive in the technology-driven globalized world (Hamsha, 2011). Now, the new 'ICT in Education' concept has a broader notion and it operates in a grander scheme as compared to the 'Smart School' initiative. The broader concept

includes amalgamating multi-lateral efforts from all stakeholders, from the Ministry of Education (MOE) level to the school and educational institution level, and especially the Community of Practice which consists of experienced teachers, industry practitioners, alumni, parents and students who can provide constructive feedback on user requirements and areas of improvement to solidify the approach of integrating ICT in education (Ministry of Education Malaysia, 2010) and MSC Malaysia would identify and support the development of niche areas in software and e-solutions, creative multimedia, shared services, outsourcing and e-business in 10th Malaysia Plan 2011–2015 (The Economic Planning Unit of Prime Minister's Department, 2010).

Moreover, the Interim Strategic Plan 2011-2020 (Ministry of Education Malaysia, 2012b) strongly emphasized the use of ICT in teaching and learning as well as in the field of administration and management of schools and educational institutions as a prerequisite for Malaysia to become a high-income nation to achieve the 10th Malaysia Plan 2011-2015 objectives. To achieve the objectives mentioned, MOE has launched a comprehensive review of the education system in order to develop a new National Education Blueprint in October 2011 (Ministry of Education Malaysia, 2012a). The Blueprint offers a vision of education system and students aspirations that Malaysia both needs and deserves, and 11 strategic or operational shifts that would be required to achieve that vision have been suggested. Among these 11 strategic, shift seven is related to the leverage of Information and Communication Technology (ICT) to scale up the quality of learning across Malaysia which provides internet access and virtual learning environment via 1-BestariNet for all 10,000 schools. Furthermore, Clause 29 & 30 in the National Education Policy effort from Educational Policy Planning and Research Division (2012) also clearly reflected on the needs of the educational system in Malaysia to the use of ICT in Teaching and Learning and Educational Management.

Murray (2013) found that school systems have access to more data than ever before but most teachers and school leaders are lack of skills to use the data for student and school improvement. Hussein (2013) stated that there appears to be a problem of lack of coordination among Malaysian educational agencies that routinely collecting some amount of the same school-related information. This practice has tended to create duplication in data collection, raising issues of questionable data reliability and extra burden to schools. Thus, he views that a more comprehensive, detailed and related information system that can digest, assimilate, interpret and use with full effectiveness is considered necessary to overcome this weakness. Besides, the information system should highlight the integration of management, administration and operations that will be required in terms of the principal alliances and the channels of communications across divisions and unit, states, districts and schools. His suggestion is in line with one of the eight key focus area covered under Policy on ICT in Education (Ministry of Education Malaysia, 2010) to have a central Educational Management System.

Following this, a new School Management System (SMS) was launched by the Education Technology Division, Ministry of Education in 2013. SMS is a simplified and resourcefully integrated system with can accomplished many management tasks (Haslina, Bahbib, & Norhisham, 2014). The main objective of this system is to create only one information management application for all school to reduce teachers' burden and to create a centralized database that can be utilized and reached by multiple users or all agencies under the MOE. This system automates two key function areas which are: (i) school management and educational administration and (ii) teaching and learning (Ministry of Education Malaysia, 2013a). School administrators and teachers used SMS to manage schools' information, whereas, at the same time parents, Ministry of Education staffs and even students can access relevant information from SMS.

According to Madiha Shah (2014), the online information system usage in educational management has increased rapidly due to its effectiveness and efficiency. He further clarified that the main purpose and usage of school management system was to improve the efficiency of school activities in term of storing students and teachers personnel data. Furthermore, he found that the overall literature review highlighted the positive impact of school management system on school management and administration which includes more efficient administration, better time management, higher utilization of school resources, reduction in workload, better accessibility to information, and

improvement in the quality of reports. Thus, technology includes all scientific techniques and processes for improving work and to be an effective user of technology, it is important for the school leaders and teachers to understand how technological advances could affect the effectiveness of school management (Munro, 2008).

### **Statements of problem**

Malaysian Government has sustained high levels of investment in education over the five decades since independence (Ministry of Education Malaysia, 2012a), but the gap between the high levels of expenditure on educational technology and the expected return in school improvement is still a global education agenda with great debate (Leong, 2010; Lu, 2013; Wahdain & Ahmad, 2014). Besides, continuous efforts are being taken to enhance teachers' ICT skill in all schools in Malaysian context (Sathiamoorthy, Leong, & Mohd Jamil, 2011), but the ICT usage in schools does not meet the expected requirement both in terms of quantity and quality (Fong, Ch'ng, & Por, 2013).

Chen (2004) and Wachira and Keengwe (2011) found that despite the proliferation of computer equipment has been provided in the school and the promise of educational technologies, a survey of teachers consistently showing declines in the educational technologies usage. Based on the MOE's study finding in 2010, only one-third of students perceive their teachers to be using ICT regularly in their teaching process and about 80% of teachers are found to spend less than one hour a week using ICT even though ICT has tremendous potential to accelerate the learning process. However, this potential has not yet been achieved (Ministry of Education Malaysia, 2012a).

Furthermore, based on the Feedback on The Auditor General's Report 2013, Series 3 (Ministry of Finance, 2014), the level of Virtual Learning Environment (VLE) usage among Malaysian teachers is very low which is in the range of 0.57% to 4.69%. This issue of low and slow uptake of technology amongst teachers brings us to one very pertinent question: What can be done to ensure that teachers do and want to accept and use technology in carrying out their routine duties as teachers? Hence, a paradigm shift is needed to maximize the potential of ICT and its application is very much expected in the minds of the school principals, the teachers and the relevant authority that is in-charge of preparing the principals and the teachers to keep abreast of the ICT fast and rapid development (Sathiamoorthy et al., 2011).

Even though ICT usage has been proven able to improve the effectiveness and productivity of many organization, but the human factor is identified as the most important determinant of the success or failure of the ICT implementation (Wahdain & Ahmad, 2014). Thus, human capital acceptance and use is one of the vital elements to ensure that all the initiatives and programs can be implemented by the right method at the right time with the right cost (Ministry of Education Malaysia, 2010).

Although information system has played a significant role in education management, resistance to it usage by public school teachers worldwide remains high (Hu, Clark, & Ma, 2003). Liew (2007) assumed that one of the main factors that might hinder the implementation of the ICT programs could be teachers' resistance to the acceptance and use of this new technologies in school and this will cause the huge investment into the developmental of the SMS may be wasted. So, in order to properly and effectively implement SMS into our public school system, teachers need to have positive attitudes and confidence toward the usage of this SMS that will motivate them to integrate it into their routine works. In other words, teachers' attitudes and believes about the usage of SMS will significantly influence their acceptance and use of SMS into their routine works. Thus, it is important to study teacher level of acceptance and use of SMS to ensure efficient and effective managing of schools in Negeri Sembilan.

Teachers have been acknowledged as the catalyst to achieve the promise of educational technology, overlooked in the implementation process was that attaining to this promise depended fundamentally on principals. Principals play the most critical role in making policymakers' visions for ICT integration and usage a reality at the national, district and school levels. However, most of the

previous studies have not pointed out how principals function as the key agents in influencing other users in ICT integration and usage (Levin & Datnow, 2012). Although there is a widespread acquiescence that leadership has important effects on teacher ICT acceptance and use, but to date, relatively little empirical study has explored this phenomenon in detail (Neufeld, Dong, & Higgins, 2007). In other words, what principals do to facilitate the computer technology integration process is a crucial variable (Brockmeier, Sermon, & Hope, 2005).

Although the principal is the key in leading the application of ICT in schools, according to Rossafri and Balakrishnan (2007), most of the principals were at a low level of skills and knowledge related to ICT and they become uncomfortable to be leaders in technology field, or they may be unsure about the effectiveness of technology leadership in school improvement. Besides, not many school principals are aware that the Ministry of Education (MOE) has made a huge investment in reducing the digital gaps in the education system today. This, in turn, causes them least responsible as technology leaders which are probably one of the contributing factors to the failure of the technology implementation in education. Are the school principals providing sufficient technology leadership to enhance teachers' ICT competency for ICT applications? Is the biggest barrier for technology implementation lies on principals' technology leadership? The main question that arises here is whether school principals demonstrate sufficient technology leadership practices.

According to Sathiamoorthy et al. (2011), when principal recognizes theirs' role in technology leadership, they can easily provide at least 30% change and enhancement towards teachers' ICT skill. At the same time, if the principal becomes more aware of the various dimensions of technology leadership along which they can contribute more to their teacher's ICT skill development and application. In another word, only when school principals are prepared for their emerging role as technology leaders, teachers will be positively influenced and supported to accept technology integration.

Many previous studies show that the application of ICT has a significant impact on teaching and learning process but there is a lack of empirical research about the information system usage in a broader range of school management which helps administrators and teachers manage information and centralize administrative tasks. Besides, the issue of principals' role as technology leaders is beginning to raise some concerns in Malaysia. However, many of the country's principals are not fully aware of their role as technology leaders and practically doing nothing about it (Sathiamoorthy, Sailesh, & Zuraidah, 2012). According to Wilmore and Betz (2000), there have been limited studies on the role of the principal and the implementation of ICT in schools. Malaysia, being a developing country, is lagging behind the developed ones in terms of the number of researches on this issue (Sathiamoorthy et al., 2011). Thus, based on the problems stated, the researcher aims to investigate the relationship between the principal technology leadership practices and teacher acceptance and use of SMS in Negeri Sembilan secondary schools.

### **Research objectives**

This study aims to investigate teachers' perception of the level of principal technology leadership practices and teacher acceptance and use of SMS in Negeri Sembilan secondary schools. The objectives of this study are as follows:

1. To analyze the level of teacher acceptance and use of SMS (endogenous variable) in Negeri Sembilan secondary schools.
2. To analyze the level of principal technology leadership practices (exogenous variable) in Negeri Sembilan secondary schools.
3. To examine the relationship between principal technology leadership practices and teacher acceptance and use of SMS in Negeri Sembilan secondary schools
4. To analyze which of the principal technology leadership practices dimensions are the significant predictors of teacher acceptance and use of SMS in Negeri Sembilan secondary schools.

- To assess the moderating effect of teacher demographic variables on the relationship between principal technology leadership practices and teacher acceptance and use of SMS in Negeri Sembilan secondary schools.

### Conceptual framework

Figure 1 depicted the conceptual framework of the study.

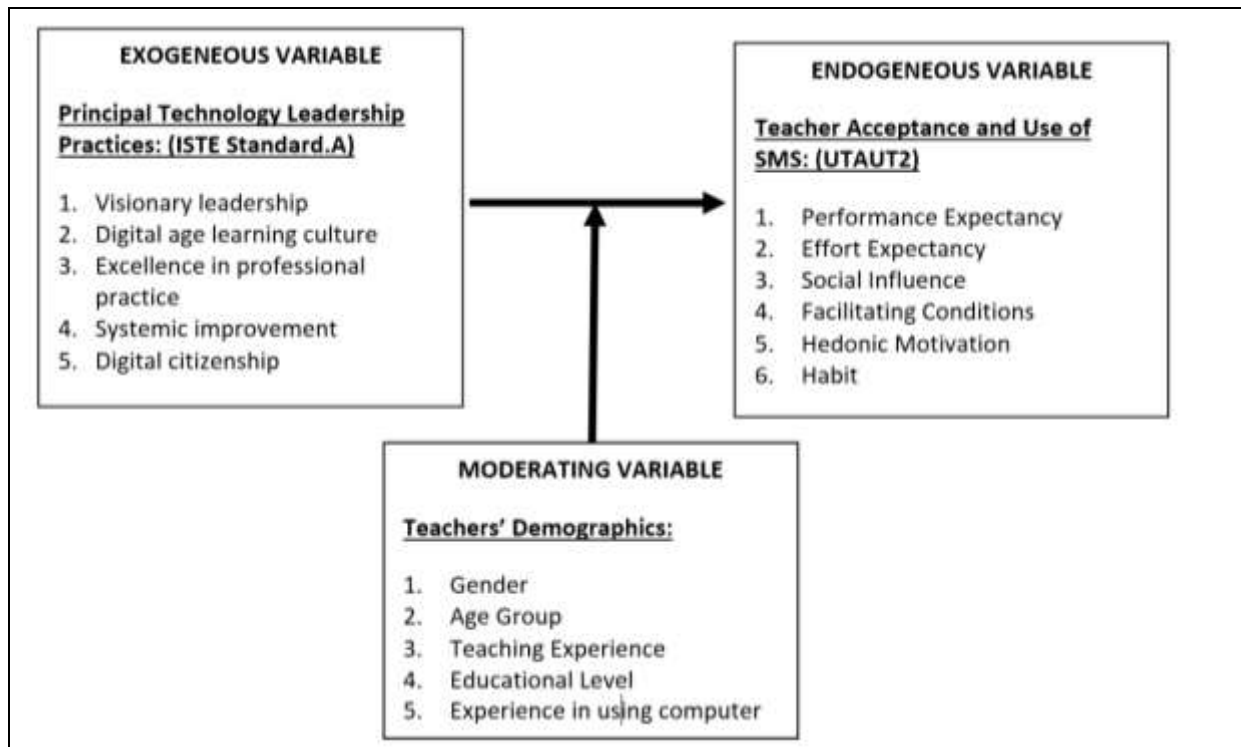

Figure 1: Conceptual framework of the study

### Methodology

#### Research design

This study aims to examine the relationship between teacher acceptance and use of SMS as the endogenous (dependent) variable with principal technology leadership practices as the exogenous (independent) variable and teacher demographic variables as the moderating variable. Thus, quantitative research method is applied to explain how one variable affects another (Creswell, 2012) or to establish a relationship between variables (Fraenkel, Wallen, & Hyun, 2011). This is a non-experimental quantitative research using survey technique through the administration of a set of questionnaire that was developed for data collection. A cross-sectional and self-administered questionnaire was the data collection tool for this research design.

#### Population and Sample of the study

The targeted population for this study was comprised of all public secondary day school teachers in Negeri Sembilan, Malaysia. There are 6499 teachers within 89 schools located in six different districts in Negeri Sembilan. The minimum number of respondents needed for this study at the significance level  $p=.05$  is 362 teachers (Krejcie & Morgan, 1970). The selection of samples for this study was conducted in several stages by probability sampling procedure which involved proportional stratified random sampling, simple random sampling and systematic random sampling. A total of 450

questionnaires were distributed to the respondents and a total of 417 questionnaires collected were analyzed, representing a valid response rate of 92.7%.

### ***Instrumentation***

A questionnaire was developed by the researcher to obtain the information needed for the study. The instrument comprised of respondent demographic variables, principal technology leadership practices, and teacher acceptance and use of SMS. Teacher demographic variables are gender, age group, teaching experience, highest educational level, and experience in using a computer.

Principal technology leadership practices were measured based on the five composite dimensions of ISTE Standards for Administrators (ISTE Standards•A) as prescribed by The International Society for Technology in Education, ISTE (2009). These dimensions are: (i) Visionary leadership; (ii) Digital age learning culture; (iii) Excellence in professional practice; (iv) Systemic improvement and (v) Digital citizenship. The instrument was developed base on the elements in the ISTE Standards•A (2009) as guideline together with the adaptation of some High Impact Malaysian School Leaders Competencies Standard elements related to technology leadership from an instrument named “*Instrumen Kompetensi Pemimpin Sekolah*” (KOMPAS) which was developed by The National Institute of Educational Leadership and Management, Institute Aminuddin Baki (Amin Senin, Abd. Razak Manaf, Rosnarizah Abd. Halim, & Abd. Jalil Abd. Hamid, 2011).

Teacher acceptance and use of SMS scale was adapted from the Unified Theory of Acceptance and Use of Technology (UTAUT2) Model (Venkatesh et al., 2012), which comprised of six dimensions: (i) Performance Expectancy; (ii) Effort Expectancy; (iii) Social Influence; (iv) Facilitating Condition; (v) Hedonic Motivation; and (iv) Habit.

The developed instrument was pilot tested using 57 secondary school teachers in some secondary schools located in the state of Selangor, Perak and Johor. Data gathered were analyzed using Statistical Package for Social Sciences (SPSS) version 22.0 for internal consistency. The results of analysis showed that the Cronbach Alpha for the principal technology leadership practices dimensions were between .908-.944, and teacher acceptance and use of SMS dimensions were in the range of .843-.926. These indicated that the instrument achieved a good level of reliability.

### ***Analysis of Data***

Numerical data gathered were analyzed quantitatively using SPSS and Analysis of Moment Structures (AMOS) version 22.0. AMOS was used for model testing based on structural equation modeling (SEM) (Chua, 2009). Both descriptive and inferential statistical methods were used to analyze the data using SPSS to answer the proposed research questions. Inferential statistics was use to generalized the results of the research sample to the population of the study (Chua 2013). Descriptive statistics in term of mean and standard deviation are used to answer the first two research questions. For inferential statistics, the Pearson product-moment correlation test was performed to examine the relationship between principal technology leadership practices and teacher acceptance and use of SMS, while the multiple regression analysis was carried out to identify which dimensions of principal technology leadership practices contribute to the changes in the teacher acceptance and use of SMS. Finally, SEM procedure with AMOS was carried out to assess the moderating effect of teacher demographic variables on the relationship between principal technology leadership practices and teacher acceptance and use of SMS in Negeri Sembilan secondary schools.

### ***Findings***

This section would presents the results of the study according to each of the research questions.

*Research Question 1; What are the levels of teacher acceptance and use of SMS in Negeri Sembilan secondary schools?*

Descriptive statistic was used to analyze the data collected from 417 teachers in Negeri Sembilan secondary schools. The analysis yield results as shown in Table 1.

Table 1: Mean, Standard Deviation and the Level of Teacher Acceptance and Use of SMS (N=417)

Dimension	Mean	Standard Deviation	Level
1) Performance Expectancy	7.03	1.49	High
2) Effort Expectancy	7.00	1.46	High
3) Social Influence	6.55	1.42	Medium
4) Facilitating Conditions	7.23	1.34	High
5) Hedonic Motivation	6.86	1.51	High
6) Habit	6.45	1.71	Medium
Overall	6.85	1.32	High

Based on Table 1 showed above, the overall mean for teacher acceptance and use of SMS is 6.85. This could be interpreted as high level of teacher acceptance and use of SMS in Negeri Sembilan secondary schools. The results of the analysis for each of the teacher acceptance and use of SMS dimensions indicated that four out of six of the teacher acceptance and use of SMS dimensions showed a high level of mean. These dimensions are performance expectancy, effort expectancy, facilitating condition, and hedonic motivation. While, the other two of the teacher acceptance and use of SMS dimensions demonstrated a medium level of mean, these dimensions are social influence and habit.

*Research Question 2: What are the levels of principal technology leadership practices in Negeri Sembilan secondary schools?*

The descriptive analysis yield results as shown in Table 2.

Table 2: Mean, Standard Deviation and the Level of Principal Technology Leadership Practices (N=417)

Dimension	Mean	Standard Deviation	Level
1) Visionary Leadership	7.22	1.32	High
2) Digital Age Learning Culture	7.30	1.35	High
3) Excellence in Professional Practice	7.09	1.33	High
4) Systemic Improvement	7.07	1.35	High
5) Digital Citizenship	7.10	1.37	High
Overall	7.15	1.26	High

From Table 2, the overall mean of principal technology leadership practices is 7.15. This could be interpreted that majority of the respondents perceived that their principals demonstrated a high level of principal technology leadership practices in Negeri Sembilan secondary schools. Two out of the five principal technology leadership practices dimensions have higher mean than the overall mean. These dimensions are Digital Age Learning Culture, and Visionary Leadership. While the other three principal technology leadership dimensions have a lower mean than the overall mean: Digital Citizenship, Excellence in Professional Practice, and Systemic Improvement. However, all the five principal technology leadership practices dimensions have mean that are interpreted as high level.

*Research Question 3: Is there a significant relationship between principal technology leadership practices and teacher acceptance and use of SMS in Negeri Sembilan secondary schools?*

The Pearson product-moment correlation test was performed to examine the relationship between principal technology leadership practices and teacher acceptance and use of SMS. The result of the analysis was presented in Table 3.

Table 3: Pearson Product-Moment Correlation Analysis between Principal Technology Leadership Practices and Teacher Acceptance and Use of SMS

Variable		Teachers' Acceptance and Use of SMS
Principals' Technology Leadership Practices	Pearson Correlation	.541**
	Sig. (2-tailed)	.000
	N	417

\*\* . Correlation is significant at the 0.01 level (2-tailed)

Table 3 showed that for the sample of this study (n=417), there is a statistically significant positive correlation which is moderately strong (r=.541, p<.01) between principal technology leadership practices and teacher acceptance and use of SMS.

*Research Question 4: Which of the principal technology leadership practices dimensions are the significant predictors of teacher acceptance and use of SMS in Negeri Sembilan secondary schools?*

The multiple regression analysis yields outputs as shown in Table 4.

Table 4: Multiple Regression (Stepwise) on Principal Technology Leadership Practices to Teacher Acceptance and Use of SMS (N=417)

Variable	(Unstad.) B	(Stand.) β	t	Sig	R <sup>2</sup>	Contribution (%)
Digital Citizenship	.370	.384	6.272	.000	.281	28.1
Visionary Leadership	.197	.198	3.227	.001	.299	1.8
Constant	2.798		8.867	.000		

The result of multiple regression analysis shown in Table 4 indicated that the prediction model contained two out of the five predictors. These predictors are digital citizenship (β=.384, p=.000<.05) and visionary leadership (β=.198, and p=.001<.05). The digital citizenship dimension was found to contribute 28.1% of the variance on teacher acceptance and use of SMS (R<sup>2</sup>=.281) while the combination of digital citizenship and visionary leadership dimension (model 2) accounted for 29.9% of the variance on teacher acceptance and use of SMS (R<sup>2</sup>=.299).

The dominant predictor for teacher acceptance and use of SMS is digital citizenship dimension (β=.384, t=6.272 and p=.000). The t-test result was significant at the significant level of p<.05 with the R<sup>2</sup>=.281, this indicated that digital citizenship dimension contributes 28.1% of variance on teacher acceptance and use of SMS. Based on the standardized beta value, when the digital citizenship dimension increase by one unit of standard deviation, teacher acceptance and use of SMS will increase by .384 unit of standard deviation.

The second predictor which contributed only 1.8% of variance to teacher acceptance and use of SMS is visionary leadership dimension (β=.198, t=3.227 and p=001). The t-test result was significant at the significant level p<.05 with the combine R<sup>2</sup>=.299, this indicated that the visionary leadership dimension contributes 1.8% (29.9% - 28.1%) of variance in teacher acceptance and use of SMS. Based on the standardized beta value, when the visionary leadership dimension increase by one unit of standard deviation, teacher acceptance and use of SMS will increase by .198 unit of standard deviation.

Table 5: Multiple Regression Analysis (Stepwise): ANOVA

	Sum of Squares	df	Mean Square	F	Sig.
--	----------------	----	-------------	---	------



Regression	217.499	2	108.750	88.234	.000
Residual	510.262	414	1.233		
Total	727.761	416			

Based on Table 5, the F-test result indicated that there is a significant relationship between the two predictor variables with teacher acceptance and use of SMS [F(2,414)=88.234, p=.000] at the significant level of  $p < .05$ . This multiple regression analysis results also showed that the combination of the two dimensions of principal technology leadership practices namely digital citizenship and visionary leadership accounted for 29.9% of the variance on teacher acceptance and use of school management system. This means that there are as many as 70.1% of the variance on teacher acceptance and use of SMS are unable to be predicted by principal technology leadership practices as it may be caused by other variables (other factors) that are not examined in this study.

*Research Question 5: Do teacher demographic variables moderate the relationship between principal technology leadership practices and teacher acceptance and use of SMS?*

Moderating variable is the variable that “moderates the effect” of an independent variable on its dependent variable, before introducing a moderator into the model, the effects of independent variable on its dependent variable must exist and significant. Figure 2 showed that there is a statistically significant effect exist between principal technology leadership practices and teacher acceptance and use of SMS. Hence, this model would be used to perform the moderating effect of teacher demographic variables on the relationship between principal technology leadership practices and teacher acceptance and use of SMS. Multi-group path analysis would be carried out to assess the effect of the moderating variable in this model.

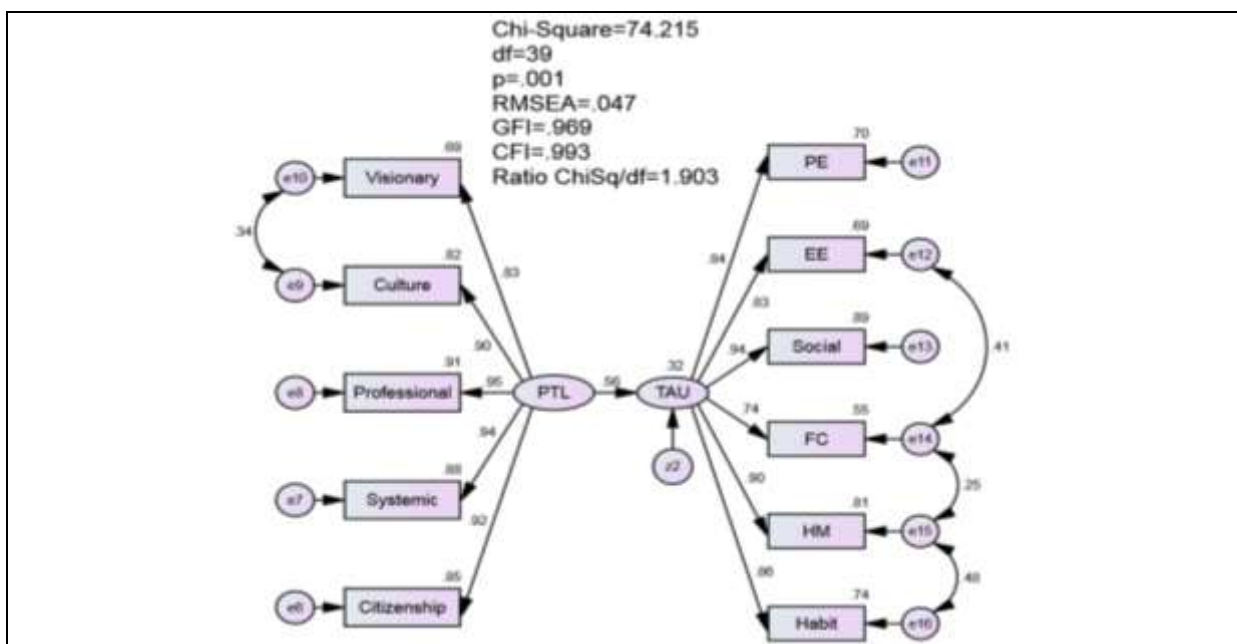

Note: PTL=Principal Technology Leadership Practices; TAU=Teacher Acceptance and Use of SMS

Figure 2: Principal technology leadership practices and teacher acceptance and use of school management system

In this study, the researcher aims to investigate the moderating effect of the teacher demographic variables in term of gender, age, educational level, teaching experience, and experience in using a computer on the relationship between principal technology leadership practices and teacher acceptance and use of SMS. The analysis yield results as presented below.

Table 6: Nested Model Comparisons (Assuming model Unconstrained Model to be correct)

Demographic Variable	Model	DF	CMIN	P
Gender	Constrained	1	.044	.834
Age	Constrained	3	5.607	.132
Educational level	Constrained	2	.076	.963
Teaching experience	Constrained	2	14.193	.001
Experience in using computer	Constrained	2	1.617	.446

Based on the Nested Model Comparisons analysis which compares the equivalence of both models for all the demographic variables shown in Table 6, it was found that the difference in the chi-squared Goodness-of-Fit between models for gender, age, educational level, and experience in using a computer are not statistically significant. This indicated that there were no statistically significant differences between groups for these four demographic variables. Hence, gender, age, educational level, and experience in using a computer are not the moderator of the relationship between principal technology leadership practices and teacher acceptance and use of SMS. However, the Nested Model Comparisons analysis showed that respondents' teaching experience is a moderator on the relationship between principal technology leadership practices and teacher acceptance and use of school management system.

## Discussions

The school is a complex organization with various functional roles and the information related to its community are overloaded (Kelly & Downey, 2011). Hence, the usage of ICT has been increasingly incorporated into school management to improve its effectiveness and efficiency (Madiha Shah, 2014; Prokopiadou, 2012). It was commonly acknowledged that the full utilization of SMS could offer invaluable support to schools, which are increasingly being granted autonomy in the school development policy (Bosker, Branderhorst, & Visscher, 2007). However, teachers need to have positive attitudes toward the acceptance and use of school management system in order to properly and effectively integrate it into their routine works. The results of this study indicated that teachers in Negeri Sembilan secondary schools demonstrated very positive attitudes toward the acceptance and use of SMS. Besides, these teachers found that performance expectancy, effort expectancy, facilitating conditions and hedonic motivation is more important factors regarding their acceptance and use of SMS compared with social influence and habit. This was supported by Wozney, Venkatesh, and Abrami (2006), who found that technology innovations are most likely to be accepted by teachers if the perceived value of the innovation usage and its' expectancy of success are high. They revealed that perceived value of innovation usage and expectancy of success was the most crucial issues in differentiating teachers' computer acceptance and usage level.

As technologies became increasingly important in educational systems and principals' role as technology leader have been explored as a way of enhancing teachers' performance and supporting effective technology integration into schools, there is a need to arise school administrators' understanding about their respond and impact toward these technological changes (Richardson, Bathon, Flora, & Lewis, 2012). The major responsibility for a principal who acts as a school leader is initiating and implementing school change through the ICT usage and able to facilitate complex decision to integrate it into teaching, learning and school administration (Afshari, Abu Bakar, Wong, Abu Samah, & Foo, 2008). The results of this study indicated that teachers in Negeri Sembilan secondary schools perceived that their principals practiced a high level of technology leadership for all the five dimensions. This finding was in line with Alan Seay (2004) who found that the principals in Texas High School demonstrated a high mean score for all the ISTE Standards•A dimensions. Similar findings were also reported by Alkrdem (2014), Eren and Kurt (2011), Faridah (2011) and Moktar (2011). This finding reflected that principals in Negeri Sembilan secondary schools have

realized their role as technology leaders and they are capable of playing technology leadership role in their daily practices as observed by their teachers.

The Pearson product-moment correlation test showed that there is statistically significant positive correlation which is moderately strong between principal technology leadership practices and teacher acceptance and use of SMS. This positive correlation revealed that if the principal practices a higher level of technology leadership, the level of teacher acceptance and use of SMS will be increased as well. Thus, principal technology leadership practices are confirmed as one of the factors that influence teacher acceptance and use of SMS. This finding was supported by the empirical study findings conducted by Fisher (2013), Franklin (2007), Hatlevik and Arnseth (2012), Jackson (2009), Leong (2010), Mohd Jamil (2011), Tan (2010), Ting (2007), and C.-h. Wang (2010) who found that principal technology leadership practices significantly influence teachers' technology usage.

Furthermore, based on the multiple regression analysis, it was found that digital citizenship and visionary leadership are the two principal technology leadership practices dimensions that are statistically significant predictors of teacher acceptance and use of SMS in Negeri Sembilan secondary schools. This finding was in line with Leong (2010) and Mohd Jamil (2011), who found that visionary leadership and digital citizenship are the significant predictors on teachers' ICT application. Hence in order to enhance teacher acceptance and use of SMS, there is a need to promote principal technology leadership according to the dimensions which have a higher impact on teacher acceptance and use. In accordance to these, technology has emerged as a major factor in leadership development and preparation program worldwide (Alan Seay, 2004; Duncan, 2011; Grey-Bowen, 2010; LaFrance & Beck, 2014; Redish & Chan, 2007; Richardson & McLeod, 2011; Sherman & Beaty, 2007; Watts, 2009) and this program would reshape how educational leaders learn, interact, and conceptualize their professional technological practices (Webber, 2003).

Finally, the moderating effect test showed that teacher demographic variables in term of gender, age, educational level, and experience in using a computer are not the moderator but teaching experience is a moderator on the relationship between principal technology leadership practices and teacher acceptance and use of SMS. This finding was in line with Inan and Lowther (2010), who also found that only teaching experience, but not age, had a significant total impact on technology integration.

## **Conclusion**

Technology has played an important role in schools around the world. More and more teachers and administrators use technology in some aspect of their daily activities. There is a tremendous need for leadership in the use of technology to ensure that it makes a valuable and lasting contribution to education.

In Malaysia, all public secondary schools are required to use School Management System (SMS) mandatory starting from 1<sup>st</sup> January 2015. Hence, in order to encourage teachers to effectively use SMS to carry out their routine work, principals play an important role as technology leaders in fostering teacher acceptance and use of SMS. Besides, policy maker should design professional development programs to cultivate the principals about the more effective and efficient utilization of technology for learning.

## **References**

- Adeyemi, T. O., & Olaleye, F. O. (2010). Information Communication and Technology (ICT) for the Effective Management of Secondary Schools for Sustainable Development in Ekiti State, Nigeria. *American-Eurasian Journal of Scientific Research*, 5(2), 106-113.
- Afshari, M., Abu Bakar, K., Wong, S. L., Abu Samah, B., & Foo, S. F. (2008). School Leadership and Information Communication Technology. *The Turkish Online Journal of Educational Technology*, 7(4), 82-91.
- Alan Seay, D. (2004). *A study of the technology leadership of Texas high school principals*. (Doctor of Education Ed.D.), University of North Texas, Ann Arbor. Retrieved from

- <http://search.proquest.com/docview/305168558?accountid=28930> ProQuest Dissertations & Theses Global database. (3126588)
- Amin Senin, Abd. Razak Manaf, Rosnarizah Abd. Halim, & Abd. Jalil Abd. Hamid. (2011). *Instrumen Kompetensi Pemimpin Sekolah (KOMPAS)*. Genting Highlands: Institute Aminuddin Baki, Ministry of Education.
- Avci Yucel, U., & Gulbahar, Y. (2013). Technology Acceptance Model: A Review of the Prior Predictors. *Journal of Faculty of Educational Science, Ankara University*, 46(1), 89-109.
- Bosker, R. J., Branderhorst, E. M., & Visscher, A. J. (2007). Improving the Utilisation of Management Information Systems in Secondary Schools. *School Effectiveness and School Improvement*, 18(4), 451-467. doi: 10.1080/09243450701712577
- Brockmeier, L. L., Sermon, J. M., & Hope, W. C. (2005). Principals' Relationship With Computer Technology. *NASSP Bulletin*, 89(643), 45-63. doi: 10.1177/019263650508964305
- Buabeng-Andoh, C. (2012). Factors influencing teachers' adoption and integration of information and communication technology into teaching: A review of the literature. *International Journal of Education and Development using Information and Communication Technology*, 8(1), 136-155.
- Chen, L.-L. (2004). Pedagogical Strategies to Increase Pre-service Teachers' Confidence in Computer Learning. *Educational Technology & Society*, 7(3), 50-60.
- Chua, Y. P. (2009). *Statistik penyelidikan lanjutan I: Ujian univariat dan multivariat. Buku 4*. Shah Alam: McGraw Hill Education.
- Chua, Y. P. (2013). *Mastering research statistics*. Shah Alam: McGraw Hill Education.
- Creswell, J. W. (2012). *Educational Research: Planning, Conducting, and Evaluating Quantitative and Qualitative Research* (Fourth ed.). Upper Saddle River, NJ: Pearson Prentice Hall.
- Duncan, J. A. (2011). *An Assessment of Principals' Technology Leadership: A Statewide Survey*. (Doctor of Philosophy Ph.D.), Virginia Commonwealth University, Ann Arbor. Retrieved from <http://search.proquest.com/docview/917240719?accountid=28930> ProQuest Dissertations & Theses Global database. (3490700)
- Educational Policy Planning and Research Division. (2012). *National Education Policy, Ministry of Education*. Shah Alam, Selangor: Giga Wise Network Sdn. Bhd.
- Fong, S. F., Ch'ng, P. E., & Por, F. P. (2013). Development of ICT Competency Standard Using the Delphi Technique. *Procedia - Social and Behavioral Sciences*, 103, 299-314.
- Fraenkel, J., Wallen, N., & Hyun, H. (2011). *How to Design and Evaluate Research in Education* (8th ed.). New York: McGraw-Hill Education.
- Franklin, C. (2007). Factors That Influence Elementary Teachers Use of Computer. *Journal of Technology and Teacher Education*, 15(2), 267-293.
- Grey-Bowen, J. E. (2010). *A study of technology leadership among elementary public school principals in Miami-Dade County*. (Doctor of Education Ed.D.), St. Thomas University, Ann Arbor. Retrieved from <http://search.proquest.com/docview/807621615?accountid=28930> ProQuest Dissertations & Theses Global database. (3427096)
- Gulbahar, Y., & Guven, I. (2008). A Survey on ICT Usage and the Perceptions of Social Studies Teachers in Turkey. *Educational Technology & Society*, 11(3), 37-51.
- Hamsha, I. (2011). *Evaluation of Multimedia Super Corridor (MSC Malaysia) Contribution in Malaysia Economy*. (Master of Science), Ritsumeikan Asia Pacific University.
- Han, C. (2002). Leadership Roles of a Pre-school Principal in the Use of Information and Communication Technology: a Hong Kong experience. *Contemporary Issues in Early Childhood*, 3(2), 293-297.
- Haslina, H., Bahbib, R., & Norhisham, M. N. (2014). Towards School Management System (SMS) Success in Teacher's Perception. *Malaysian Online Journal of Educational Technology*, 2(4), 50-60.
- Hatlevik, O. E., & Arnseth, H. C. (2012). ICT, Teaching and Leadership: How do Teachers Experience the Importance of ICT-Supportive School Leaders? *Nordic Journal of Digital Literacy*, 7(1), 55-69.
- Haughey, M. (2006). The impact of computers on the work of the principal: changing discourses on talk, leadership and professionalism. *School Leadership & Management*, 26(1), 23-36. doi: 10.1080/13634230500492897

- Haydn, T., & Barton, R. (2008). 'First do no harm': Factors influencing teachers' ability and willingness to use their subject teaching. *Computer & Education, 51*, 439-447.
- Hu, P. J.-H., Clark, T. H. K., & Ma, W. W. (2003). Examining Technology Acceptance by School Teachers: A Longitudinal Study. *Information & Management, 41*, 227-241.
- Hussein, A. (2013). *Mission of Public Education in Malaysia*. Kuala Lumpur: University of Malaya Press.
- Inan, F. A., & Lowther, D. L. (2010). Factors Affecting Technology Integration in K-12 Classroom: A Path Model. *Educational Tech Research Dev, 58*, 137-154.
- International Society for Technology in Education. (2009). *ISTE Standards Administrators*.
- Jackson, D. A. B. (2009). *Relationship Between Principals' Technological Leadership and Their Schools' Implementation of Instructional Technology*. (Doctor of Education), Georgia Southern University, Statesboro Georgia.
- Kelly, A., & Downey, C. (2011). Professional attitudes to the use of pupil performance data in English secondary schools. *School Effectiveness and School Improvement, 22*(4), 415-437.
- Krejcie, R. V., & Morgan, D. W. (1970). Determining Sample Size For Research Activities. *Educational And Psychological Measurement, 30*, 607-610.
- LaFrance, J. A., & Beck, D. (2014). Mapping the Terrain: Educational Leadership Field Experiences in K-12 Virtual Schools. *Educational Administration Quarterly, 50*(1), 160-189.
- Leong, M. W. (2010). *Principal Technology Leadership and The Level of ICT Application of Teachers at A Secondary School in Seremban District*. (Unpublished Master's Thesis), University of Malaya, Kuala Lumpur.
- Levin, J. A., & Datnow, A. (2012). The principal role in data-driven decision making: using case-study data to develop multi-mediator models of educational reform. *School Effectiveness and School Improvement, 23*(2), 179-201. doi: 10.1080/09243453.2011.599394
- Liew, V. K. (2007). ICT In Education - An Action Learning Approach Using Soft System Methodology. *Educational Management and Leadership, 17*(2), 17-37.
- Lu, H. Y. (2013). *Technology Integration and Pedagogical Innovations in Malaysia Higher Education Institutions*. (Unpublished Doctoral Dissertation), University of Malaya, Kuala Lumpur.
- Madiha Shah. (2014). Impact of management information systems (MIS) on school administration: What the literature says. *Procedia - Social and Behavioral Sciences, 116*, 2799-2804.
- Ministry of Education Malaysia. (2010). *Policy on ICT in Education Malaysia*. Putrajaya: Ministry of Education.
- Ministry of Education Malaysia. (2012a). *Executive Summary Malaysia Education Blueprint 2013-2025 (Preschool to Post-Secondary Education)*. Putrajaya: Ministry of Education.
- Ministry of Education Malaysia. (2012b). *Interim Strategic Plan 2011-2020*. Putrajaya.
- Ministry of Education Malaysia. (2013a). *Implementation Plans For The Expansion of School Management System As A Solutions in Addressing Teacher Workload Issues and An Integrated Educational Data*. Putrajaya: Ministry of Education.
- Ministry of Education Malaysia. (2013b). *Malaysia Education Blueprint 2013-2025 (Preschool to Post-Secondary Education)*. Putrajaya.
- Ministry of Finance. (2014). *Feedback on The Auditor General's Report, Series 3*. Putrajaya: Ministry of Finance.
- Mohd Jamil, S. (2011). *Principals' Technology Leadership in A Smart School in Kota Tinggi, Johor*. (Unpublished Master's Thesis), University of Malaya, Kuala Lumpur.
- Munro, J. H. (2008). *Roundtable Viewpoints: Educational Leadership* (First ed.). New York: McGraw-Hill.
- Murray, J. (2013). Critical issues facing school leaders concerning data-informed decision-making. *School Leadership & Management: Formerly School Organisation, 33*(2), 169-177.
- Neufeld, D. J., Dong, L., & Higgins, C. (2007). Charismatic leadership and user acceptance of information technology. *European Journal of Information Systems, 16*(4), 494-510.
- Omoogun, A. C., Ephraim, P. E., & Omoogun, R. (2013). Impediments to the Adoption of Information and Communication Technology (ICT) in Teacher Preparation Programme. *International Journal of Education, 5*(3), 11-19.

- Papa, R. (2011). *Technology Leadership for School Improvement*. Thousand Oaks, CA: Sage Publication, Inc.
- Prokopiadou, G. (2012). Using Information and Communication Technologies in School Administration: Researching Greek Kindergarten Schools. *Educational Management Administration & Leadership*, 40(3), 305-327.
- Raman, A., Yahya Don, & Kasim, A. L. (2014). The Relationship between Principals' Technology Leadership and Teachers' Technology Use in Malaysian Secondary Schools. *Asian Social Science*, 10(18), 30-36.
- Redish, T., & Chan, T. C. (2007). Technology Leadership: Aspiring Administrators' Perceptions of Their Leadership Preparation Program. *Electronic Journal for the Integration of Technology in Education*, 6, 123-139.
- Richardson, J. W., Bathon, J., Flora, K. L., & Lewis, W. D. (2012). NETS.A Scholarship: A Review of Published Literature. *Journal of Research on Technology in Education*, 45(2), 131-151.
- Richardson, J. W., & McLeod, S. (2011). Technology Leadership in Native American Schools. *Journal of Research in Rural Education (Online)*, 26(7), 1-14.
- Rossafri, M., & Balakrishnan, M. (2007). Translating Technology Leadership to Create Excellent Instructional Leadership. *Educational Leadership and Management Journal*, 17(2), 91-103.
- Sathiamoorthy, K., Leong, M. W., & Mohd Jamil, S. (2011). *Principal Technology Leadership and Teachers' ICT Applications in two different school settings in Malaysia*. Paper presented at the International Conference on Application of ICT in economy and education (icaictee), UNWE, Sofia, Bulgaria.
- Sathiamoorthy, K., Sailesh, S., & Zuraidah, A. (2012). Principal's Strategies for Leading ICT Integration: The Malaysian Perspective. *Creative Education*, 3, 111-115.
- Sherman, W. H., & Beaty, D. M. (2007). The use of distance technology in educational leadership preparation programs. *Journal of Educational Administration*, 45(5), 605-620.
- Tan, S. C. (2010). *Technology leadership: Lessons from empirical research*. Paper presented at the facility 2010 Sydney, Sydney, Australia.
- The Economic Planning Unit of Prime Minister's Department. (2010). *Tenth Malaysia Plan 2011-2015*. Putrajaya: The Economic Planning Unit of Prime Minister's Department.
- Ting, S. T. (2007). *ICT Usage Among Teachers in the District of Sarikei Secondary Schools, Sarawak* (Unpublished Master's Thesis), University of Malaya, Kuala Lumpur.
- Venkatesh, V., Thong, J. Y. L., & Xu, X. (2012). Consumer Acceptance and Use of Information Technology: Extending The Unified Theory of Acceptance and Use of Technology. *MIS Quarterly*, 36(1), 157-178.
- Wachira, P., & Keengwe, J. (2011). Technology Integration Barriers: Urban School Mathematics Teachers Perspectives. *Journal of Scientific Educational Technology*, 20, 17-25.
- Wahdain, E. A., & Ahmad, M. N. (2014). User Acceptance of Information Technology: Factors, Theories and Applications. *Journal of Information Systems Research and Innovation*, 6, 17-25.
- Wan Mustama, W. A. H., Ahmad Rafee, C. K., Mazlan, S., & Elhammi, A. (2004). Integration of ICT in Educational Management and Leadership: Issues and Challenges. *Journal of Educational Management and Leadership*, 14(2), 47-62.
- Wang, C.-h. (2010). Technology Leadership among School Principals: A Technology-Coordinator's Perspective. *Asian Social Science*, 6(1), 51-54.
- Watts, C. D. (2009). *Technology leadership, school climate, and technology integration: A correlation study in K-12 public schools*. (Doctor of Education Ed.D.), The University of Alabama, Ann Arbor. Retrieved from <http://search.proquest.com/docview/304825524?accountid=28930> ProQuest Dissertations & Theses Global database. (3369776)
- Webber, C. F. (2003). Technology-mediated leadership development networks: Expanding educative possibilities. *Journal of Educational Administration*, 41(2), 201-218.
- Wilmore, D., & Betz, M. (2000). Information Technology and schools: the principal's role. *Educational Technology & Society*, 3(4), 12-19.
- Wong, S. L., Mas Nida, M. K., Abu Daud, S., & Othman, T. (2011). *Technology & Education: Issues, Empirical Research and Applications* (First ed.). Serdang: Universiti Putra Malaysia Press.

Wozney, L., Venkatesh, V., & Abrami, P. C. (2006). Implementing Computer Technologies: Teachers' Perceptions and Practices. *Journal of Technology and Teacher Education*, 14(1), 173-207.